

UNINTERRUPTIBLE POWER SUPPLY

# MASTER HP - UL

55 – 100Ah BATTERY CABINET

## *User Manual*



RIELLO ELETTRONICA  **riello ups**

RPS SpA  
Viale Europa 7  
37045 Legnago (VR) Italy  
[www.riello-ups.com](http://www.riello-ups.com)



# TABLE OF CONTENTS

<b>SECTION 1</b> .....	<b>3</b>
INTRODUCTION .....	3
<b>SECTION 2</b> .....	<b>5</b>
SAFETY WARNINGS.....	5
<b>SECTION 3</b> .....	<b>8</b>
BATTERY CABINET SETUP.....	8
FLOOR LOAD-CARRYING CAPACITY .....	8
CLEARANCEs.....	8
HANDLING THE CABINET (unloading and transporting).....	8
INSPECTING THE EQUIPMENT .....	10
<b>SECTION 4</b> .....	<b>11</b>
INSTALLATION AND ASSEMBLY OF BATTERY BLOCKS.....	11
BATTERY ASSEMBLY MODE.....	11
REMOVE TRAYS.....	12
POSITIONING AND INSTALLING BATTERIES.....	12
TRAY ASSEMBLY PROCEDURE.....	13
CONNECTION BETWEEN THE TRAYS.....	15
<b>SECTION 5</b> .....	<b>19</b>
CONNECTION TO UPS SYSTEM.....	19
POWER CABLE CONNECTION .....	19
AUXILIARY CABLES CONNECTIONS (OPTION).....	22

## SECTION 1

### INTRODUCTION

The BBX battery cabinet is used along with the Uninterruptible Power Supply (UPS), series MHT, to prevent loss of valuable electronic information and minimize equipment downtime. During brownouts, blackouts, and other power interruptions, batteries provide emergency power to safeguard operation.

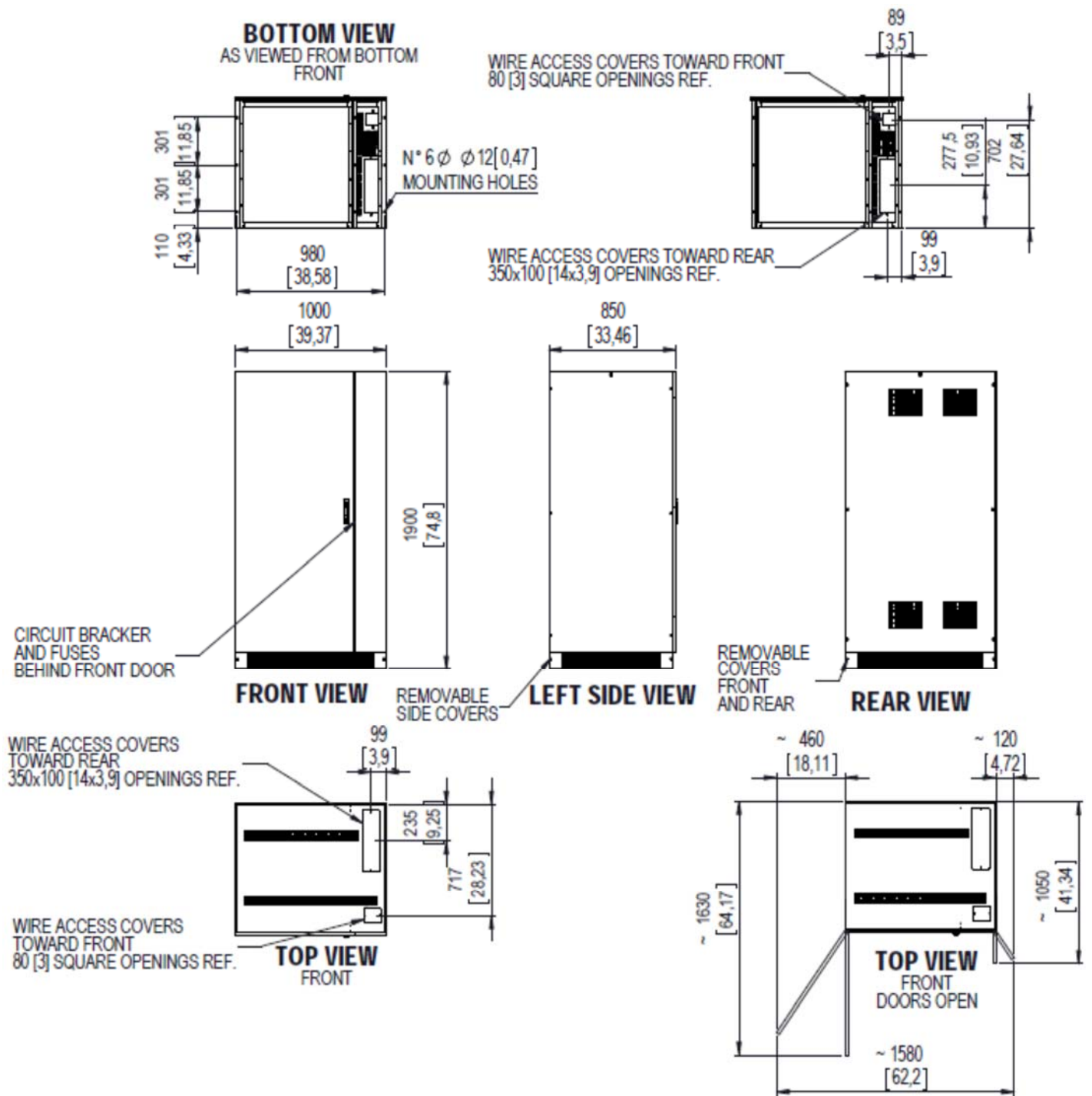

This manual is intended to describe all steps for installing the battery cabinet, starting from the empty cabinet as it is presented without battery blocks installed.  
**Fig. 1 - BBX battery cabinet external dimensions**

cabinet as it is presented without battery blocks installed.

This manual cover the versions.

BBX 1900 480V UL L6 3U :

55 Ah Rated Voltage 480Vdc (240 cells 40x 12Vdc blocks) OCP 200 A (Circuit bracker provided) . Suitable for up to 80kVA MHT UPS

BBX 1900 480V UL L8 3U :

100 Ah Rated Voltage 480Vdc (240 cells 40x 12Vdc blocks) OCP 300 A (circuit breaker provided). Suitable up to 160kVA MHT UPS, up to 500kVA with 2 or more strings

## SECTION 2

### SAFETY WARNINGS







**IMPORTANT SAFETY INSTRUCTIONS  
SAVE THESE INSTRUCTIONS**

This manual contains important instructions that you should follow during installation and maintenance of the Battery Cabinet. Please read all instructions before operating the equipment and save this manual for future reference. For any installation and maintenance, please refer this manual together with the UPS user's manual. The battery cabinet has been specifically designed for industrial or computer room applications.

#### READ AND FOLLOW ALL SAFETY INSTRUCTIONS

- a. Do not use outdoors.
- b. Do not route wiring across or near hot surfaces.
- c. Do not install near gas or electric heaters.
- d. Use caution when servicing batteries. Battery acid can cause burns to skin and eyes. If acid is spilled on skin or in eyes, flush with abundant fresh water and contact a physician immediately.
- e. Equipment should be installed where it will not readily be subjected to tampering by unauthorized personnel.
- f. The use of accessory equipment not recommended by the manufacturer may cause an unsafe condition.
- g. Do not use this equipment for other than intended use.

Table 1 - symbols

	Danger / Risk of Electric Shock
	Risk of Explosion
	Risk of fire
	Caution
	Electrostatic Sensitive Device
	Note
	Ground Connection

## DANGER



This equipment contains HIGH VOLTAGE can cause personal injury or death. All repairs and service should be performed by AUTHORIZED SERVICE PERSONNEL ONLY. There are NO USER SERVICEABLE PARTS inside the Battery Cabinet.

## WARNING



This equipment contains its own energy source (batteries). Hazardous voltage may be present even when the battery cabinet is not connected to a power source.

To reduce the risk of fire or electric shock, install this battery cabinet in a temperature and humidity controlled, indoor environment, free of conductive contaminants. Do not operate near water or excessive humidity (95% maximum).

## CAUTION



Batteries can present a risk of electrical shock or burn from high short circuit current. Observe proper precautions. Servicing should be performed by qualified service personnel knowledgeable of batteries and required precautions. Keep unauthorized personnel away from batteries.

Risk of explosion if batteries are replaced by an incorrect type. Replace with same type and rating only.



Proper disposal of batteries is required. Refer to your local codes for disposal requirements.

Never dispose of batteries in a fire. Batteries may explode when exposed to flame

This product contains Valve Regulated Sealed Acid Batteries.



**Do not open or mutilate batteries. Released material is harmful to the skin and eyes. It may be toxic**

These batteries contain lead, a neurotoxin, and sulfuric acid, a corrosive. Additionally, the energy stored in the batteries can present a shock hazard and a burn hazard. **Batteries should only be serviced by trained personnel.**

**A battery can present a risk of electrical shock and high short-circuit current.**

**The following precautions should be observed when working on batteries:**

- a) **Remove watches, rings, or other metal objects**
- b) **Use tools with insulated handles.**
- c) **Wear rubber gloves and boots.**
- d) **Do not lay tools or metal parts on top of batteries.**
- e) **Disconnect charging source prior to connecting or disconnecting battery terminals.**
- f) **Determine if battery is inadvertently grounded. If inadvertently grounded, remove source from ground. Contact with any part of a grounded battery can result in electrical shock. The likelihood of such shock can be reduced if such grounds are removed during installation and maintenance (applicable to equipment and remote battery supplies not having a grounded supply circuit).**

Contact with electrolyte requires flushing with a generous amount of clean water. Seek medical attention immediately following contact with electrolyte.

Unwanted batteries must be recycled and should never be discarded.

The life expectancy of batteries is temperature dependence at which they are stored and operated. Batteries should be used in a 70 F (21 C) environment. Consider that for every 15 F (8.3 C) increase in temperature, the life expectancy is halved.

Exposure to temperatures in excess of 90 F (32 C) should be limited to no more than 30 days per year. Under no circumstances should the battery be exposed to temperatures over 104 F (40 C) which can lead to thermal runaway, a condition that damages the battery. Thermal runaway can cause batteries to swell and if the battery body burst, the hazardous contents may be exposed.

**MAINTAINING PROPER AMBIENT TEMPERATURE USUALLY REQUIRES INSTALLING THE PRODUCT IN A TEMPERATURE CONTROLLED SPACE. EQUIPMENT ROOMS WITHOUT COOLING SYSTEMS DO NOT GENERALLY MAINTAIN THE PROPER CONDITIONS FOR GOOD BATTERY LIFE.**

## SECTION 3

### BATTERY CABINET SETUP

This section describes:  
 Floor load-carrying capacity and clearances  
 Handling the cabinet  
 Equipment inspection

#### FLOOR LOAD-CARRYING CAPACITY

When planning the commissioning, consider the battery cabinet weight for floor where it will be placed. The load-carrying capacity of the installation surface must be adequate for point and distributed loading. The approximate weights are shown in the following table.

Table 2 - Floor Load-carrying capacity

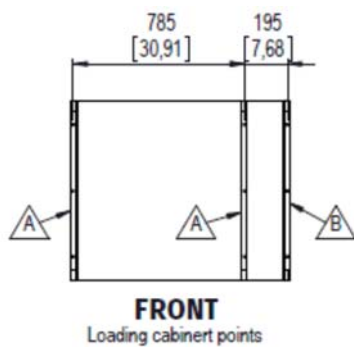

Battery Cabinet with batteries 100Ah		
Maximum Weight	Point Loading	
1750kg (3859 lbs)	A	3.8kg/cm <sup>2</sup> (54lb/in <sup>2</sup> )
	B	1.3kg/cm <sup>2</sup> (12lb/in <sup>2</sup> )
Battery Cabinet with batteries 55Ah		
Maximum Weight	Point Loading	
1150kg (2536 lbs)	A	2.5kg/cm <sup>2</sup> (36lb/in <sup>2</sup> )
	B	0.8kg/cm <sup>2</sup> (11lb/in <sup>2</sup> )
Battery Cabinet without batteries		
Maximum Weight	300kg (662 lbs)	

#### CLEARANCES

The following clearances are recommended for the Battery Cabinet.

Front of Cabinet	150 cm (59") working space 
Back of Cabinet	15.2 cm (6")

#### HANDLING THE CABINET (unloading and transporting)

The cabinet can be shipped including the batteries installed inside or without batteries. On table 2 are reported the weights of cabinets, with and without battery blocks installed.

Unloading and transporting of cabinet must be carried out with appropriate forklift. See fig. 3 for the correct way to lift the cabinet.



**CAUTION** to move the cabinet make sure to use a forklift with appropriate characteristics, rated for the cabinet weight.  
 Unloading the cabinet requires at least two people to safely remove the cabinet from the pallet

To remove the battery cabinet from ship pallet:

- 1) Make sure the path traveled has sufficient support for the combined weight of the forklift and the battery cabinet.



- 2) Remove N.6 10mm lag bolts securing the cabinet to the pallet. (N.3 for side see Fig. 2).
- 3) See Fig. 3 to identify the correct area for the insertion of the forks.
- 4) Make sure forks are at maximum separation
- 5) Keep the people out of the area of possible fall of the cabinet, during unloading and through path of destination.
- 6) Lift the cabinet with forklift 1 or 2 inches 1"- 2" (2.5-5cm) from the floor level
- 7) Carefully move the cabinet to location where will be installed and slowly drop-off it to the floor or other appropriate flat surface.

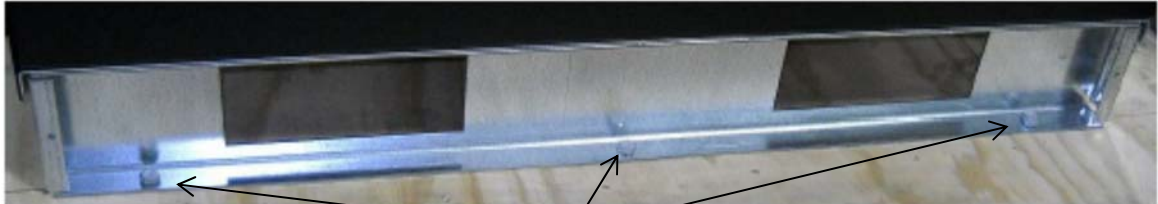

**Fig. 2 - lag bolts**

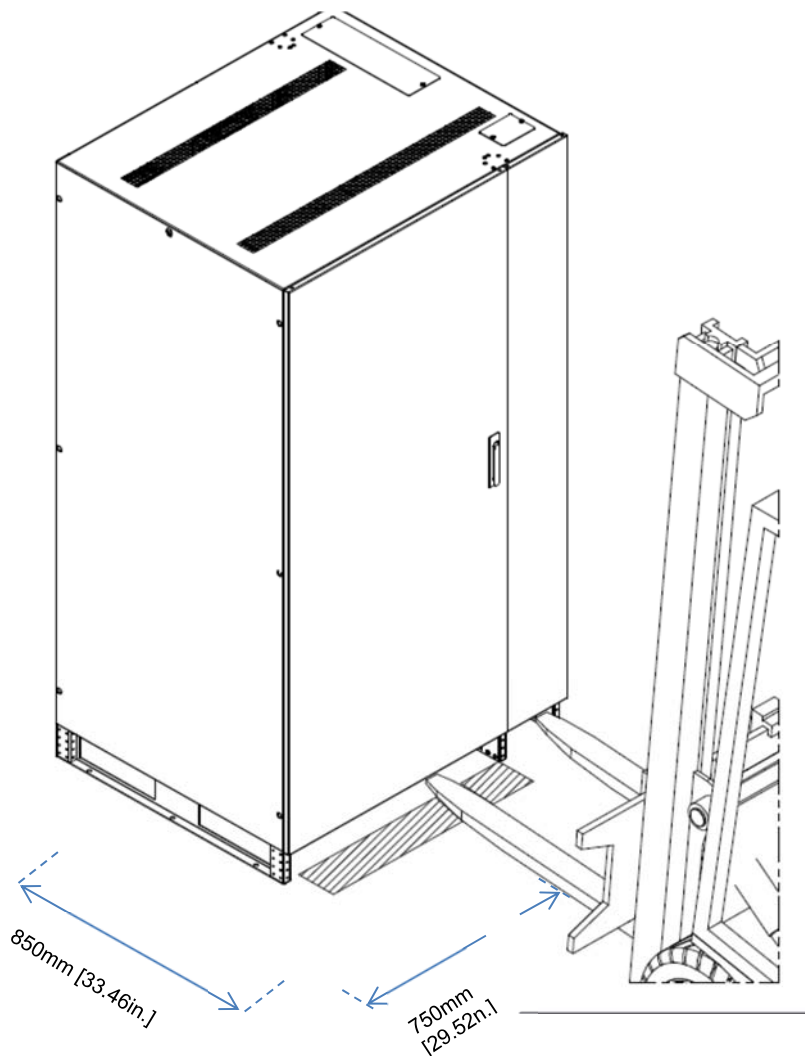
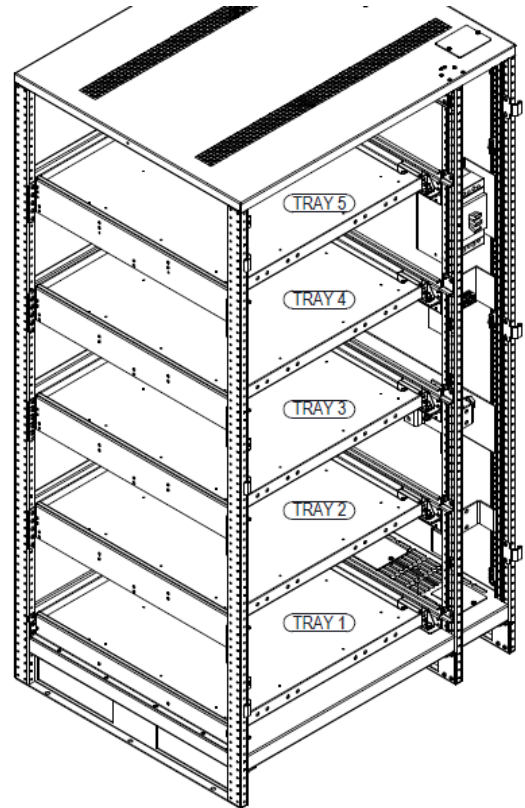

**Fig. 3 - position the forks in the indicated area**

## INSPECTING THE EQUIPMENT

If Battery cabinet is not provided with battery blocks installed:  
Remove all panels (front, rear, left and right side).

See in the figure the appearance of the cabinet without panels.



The components used for the assembly of battery blocks are always provided and you'll find the followings inside the cabinet:

Pos.#

- 1) Cable 1/0 or #2x1/0 AWG length 360mm (14.17 in.) crimped to "green" or "grey" connector at one side - 6pcs
- 2) Cable 1/0 or #2x1/0 AWG length 360mm (14.17 in.) crimped to "red" connector at one side – 2pcs
- 3) Cable 1/0 or #2x1/0 AWG length 360mm (14.17 in.) crimped to "blue" connector at one side – 2pcs
- 4) Red and black cable #2x 22 AWG style 1015 800mm (31.5 in.)
- 5) Shielded cable #2x 22 AWG style 4516 25m (82 ft) (Option)
- 6) 2 x Cable #2x22 AWG style 2516
- 7) Cu busbar marked "1" N. 10
- 8) Cu busbar marked "2" N. 20
- 9) Cu busbar marked "3" N. 5
- 10) Cu busbar marked "4" N. 10
- 11) Screws washers and spring washer to connect busbars to battery terminals
- 12) Insulated tubing to protect battery terminal connections (cut into 10 pieces about 100mm-3,9 ft-long)
- 13) Cable tie to close insulated tubing n. 20
- 14) Straps to secure battery blocks n. 25
- 15) Insulating sheet – 5pcs



If Battery cabinet is provided with battery blocks installed, don't remove panels.  
Find position 5) and 6) only.

Go to section 5

## SECTION 4

### INSTALLATION AND ASSEMBLY OF BATTERY BLOCKS

The following operations must be performed by properly trained and qualified personnel, within a suitable area with no access to other people



## WARNING!

When all the cells are connected, the voltage to the terminals could exceed 500Vdc and it is dangerous.  
 Risk of electric shock or burns due to accidental short circuits  
 Appropriate eye protection must be worn to prevent injuries from accidental electrical arcs  
 Risk of electrolyte leakage from batteries.  
 Appropriate protective clothing and accident prevention shoes must be worn to handling batteries  
 Remove all metal wearable objects (rings, watches, bracelets, necklaces...)  
 Appropriate eye protections must be worn  
 Tools with insulated handles only must be used  
 If electrolyte, leaking from batteries, comes into contact with the skin, wash immediately the part with abundant clean water

Type of batteries to be used				
Cabinet size / model	Manufacturer	P/N	n. of units	Cells per unit / unit rated voltage
100 Ah / BBX 1900 480V UL L8 3U	CSB BATTERY	HRL 12390W-FR	40	6 / 12
	FIAMM	12 FLX400 12FLB400		6 / 12
55 Ah / BBX 1900 480V L6 3U	CSB BATTERY	HRL 12200W-FR	40	6 / 12
	FIAMM	12 FLX200 12FLB200		6 / 12

### BATTERY ASSEMBLY MODE

Following the steps below, mount 8 batteries for each of the 5 trays. 40 batteries in total

Battery dimensions max	55Ah	100Ah
L mm [in]	229 [9,01]	344.5 [13.56]
H mm [in]	212 [8.35]	220 [8.66]
W mm [in]	138 [5,43]	174 [6.85]
Weight kg [lb]	18 [39,7]	35.5 [7.2]

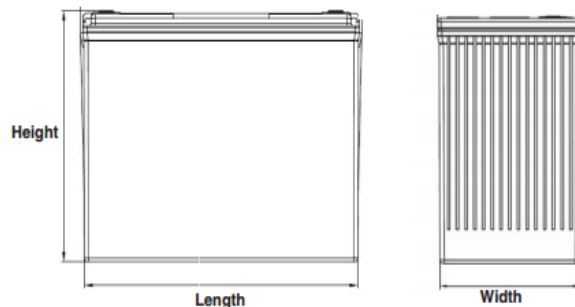

## REMOVE TRAYS

1. To facilitate the assembly operations, all the trays, except the number 1, can be removed and assembled out of cabinet
2. Remove the tray block, on both sides, remove the screws as shown in Fig. 5; on each block is stamped the number referred to tray (see Fig. 4 for tray numbers)
3. Pull off the trays N. 2-3-4-5  
Arrange n.4 straps (listed pos.14) as shown in Fig. 6. These will be used to ensure the battery blocks once assembled.

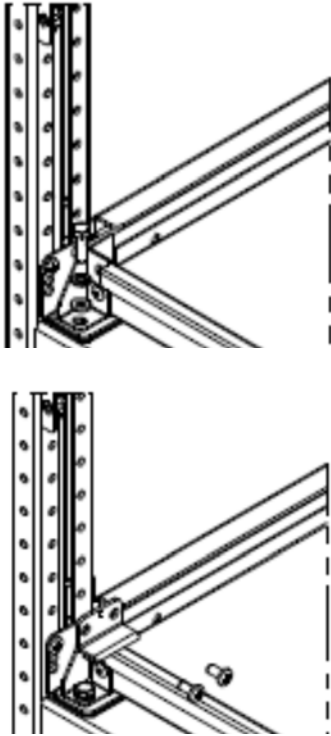

Fig. 5 - screws for tray block

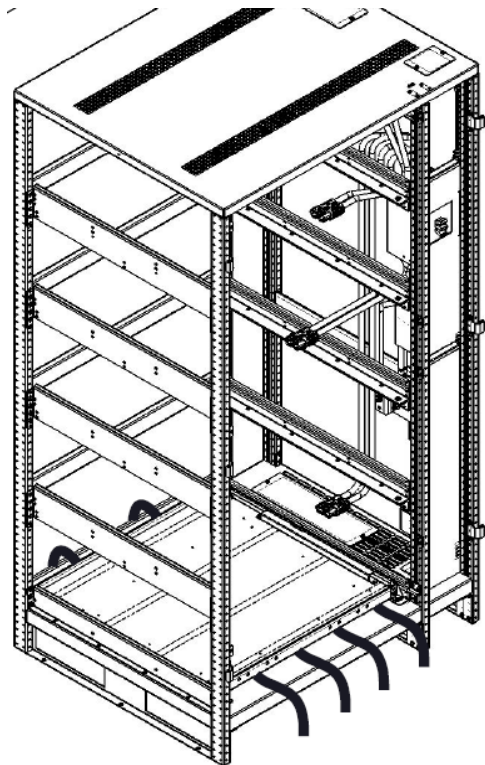

Fig. 6 - straps

## POSITIONING AND INSTALLING BATTERIES

Use the components supplied inside the cabinet and listed in the previous section (position 1÷15) to assemble the trays, following the procedure below. See the " Table 3- torque values " to connect busbars to batteries blocks terminal and lugs to busbar terminal.

Tray n.1 must be assembled inside the cabinet

Trays n. 2-3-4-5: to facilitate the assembly, the operations can be performed out of the cabinet. The assembled trays must be placed inside the cabinet using a forklift (Fig. 12)

The assembled trays must be placed in the cabinet proceeding from the lowest (tray n.2) to highest (tray n.5)

## TRAY ASSEMBLY PROCEDURE

Place n. 8 batteries on the tray positioned as shown in Fig. 7-7bis

Tighten each row of batteries using the straps provided (pos. 14) as shown in Fig. 7-7bis

Connect the busbars provided (pos. 7÷10) as shown in Fig. 8 (see the number stamped on each bars).

Put the insulating sheet provided on the assembled tray for covering bare bus bars and terminals, Fix the insulating sheet with cables ties, Fig. 10.

Assembled tray n. 1 only: connect one end of the red cable at terminal (+), black cable at terminal (-) of batteries blocks shown in Fig. 8 and the other end to the cable coming from AUX fuse holder (see electric drawing). Put and fix the insulating sheet on batteries after tray is assembled. (Fig. 10)

Insert an insulating protective tubing (pos.12) through each of the cables of positions 1÷3. Once connected the cable, pos.5, fasten tubing over the terminal using a cable-tie.

Connect Positive (+) and negative (-) terminal of the assembled tray with a cable (pos.1÷3) having colored connector at one side (fig.5). Choose the color of the connector according with number of the tray and polarity as described below:

Tray n. 1 terminal (+) "grey" or "green"; terminal (-) "blue"

Tray n. 2 terminal (+) "grey" or "green"; terminal (-) "grey" or "green".

Tray n. 3 terminal (+) "red"; terminal (-) "grey" or "green".

Tray n. 4 terminal (+) "grey" or "green"; terminal (-) "blue"

Tray n. 5 terminal (+) "red"; terminal (-) "grey" or "green".

**Table 3- torque values**

Torque at battery block terminal		
Manufacturer	Category Number	Torque
CSB BATTERY	HRL 12390W-FR	12.45Nm / 9lbf-ft
FIAMM	12 FLX400 12FLB400	5.5Nm / 4lbf-ft
CSB BATTERY	HRL 12200W-FR	12.45Nm / 9lbf-ft
FIAMM	12 FLX200 12FLB200	5.5Nm / 4lbf-ft

Torque at Bus Bar terminal	
Screw M8 cl. 8.8	23Nm / 17lbf-ft

Torque at Tray fixing	
Screw M6 cl. 8.8	9,5Nm / 7lbf-ft



**Before positioning tray check for the characteristics of the forklift**

300kg~ [661lb~]	total weight tray
150mm [6in]	minimum height from the floor
1550mm [61in]	maximum height from the floor

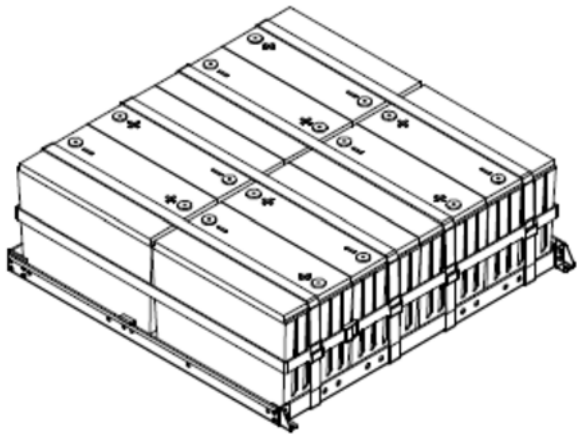

Fig. 7 - 100Ah tray

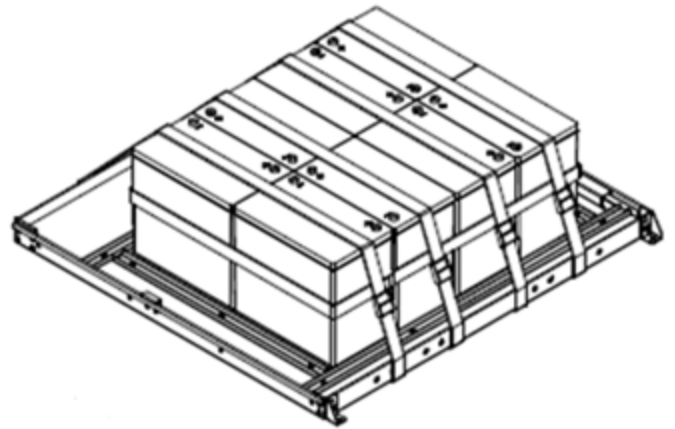

Fig. 7bis - 55Ah

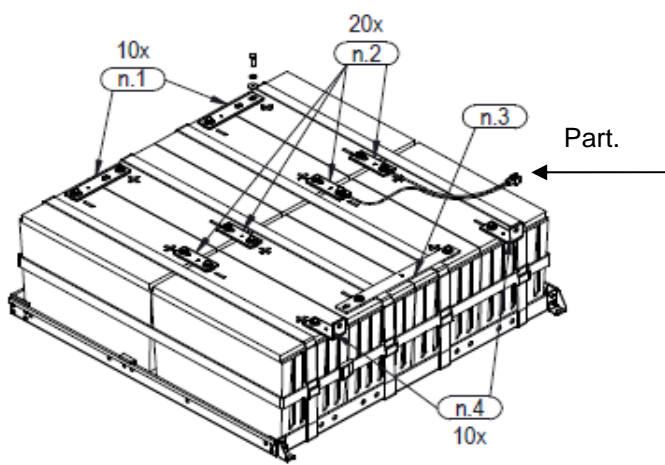

Fig. 8 - bus bars references

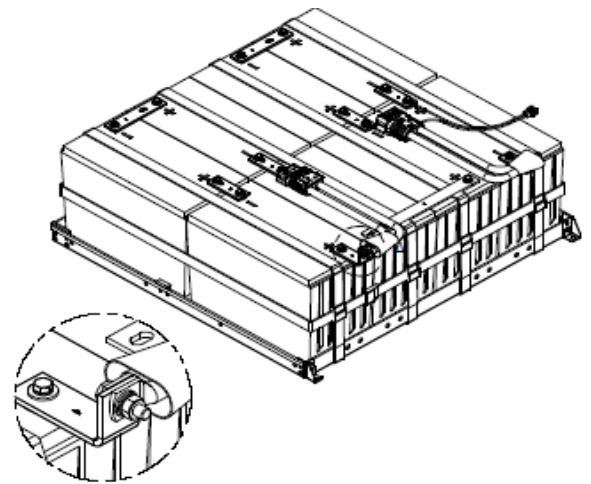

Fig. 9 - battery tray assembled

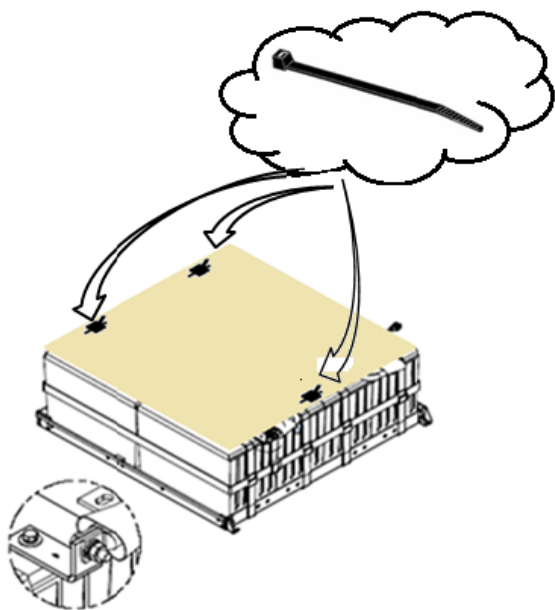

Fig. 10 - Insulating sheet fixed with cable ties for covering bare bars of batteries

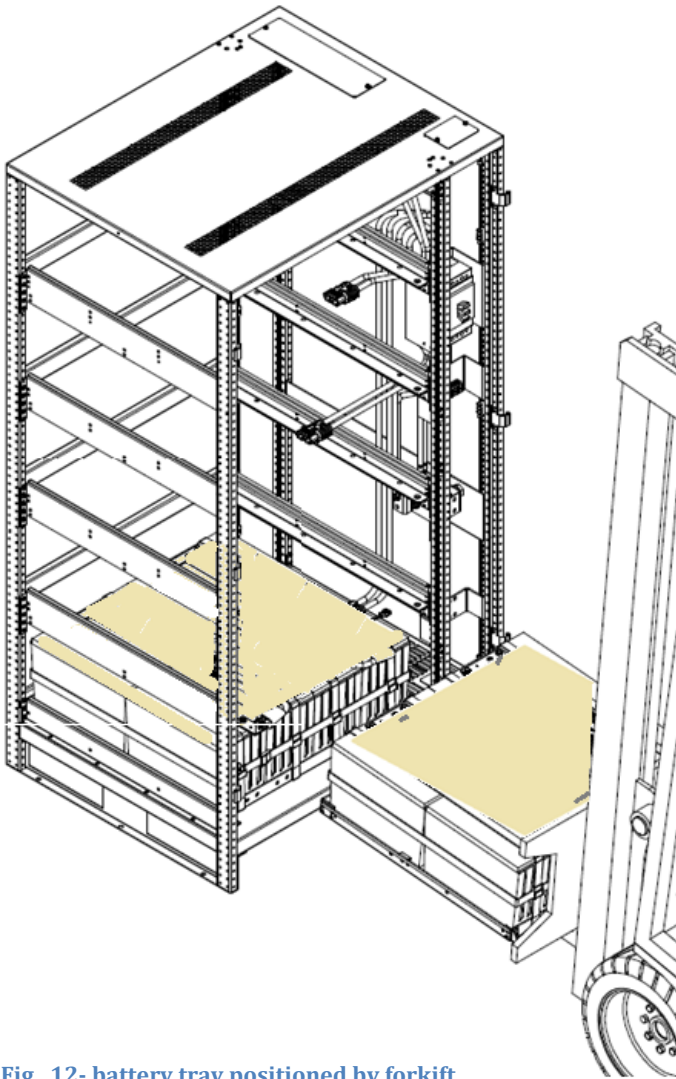

Fig. 12- battery tray positioned by forklift

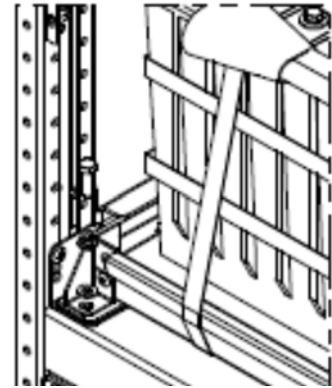
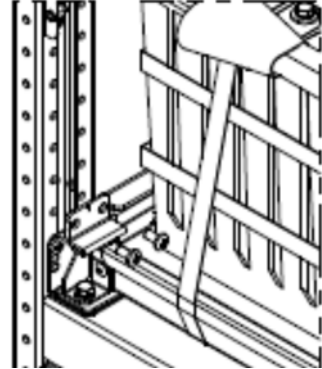

Fig. 11- detail of fastening

## CONNECTION BETWEEN THE TRAYS



**Make sure battery circuit breaker is open before operating**

FROM	TO	DESCRIPTION
TRAY 1	TRAY 2	Connect each other the grey (or green) connectors
TRAY 1	CIRCUIT BREAKER	Connect the blue connectors
TRAY 2	TRAY 3	Connect grey (or green) connectors
TRAY 3	CIRCUIT BREAKER	Connect the red connectors
TRAY 4	CIRCUIT BREAKER	Connect the blue connectors
TRAY 4	TRAY 5	Connect the grey (or green) connectors
TRAY 5	CIRCUIT BREAKER	Connect the red connectors

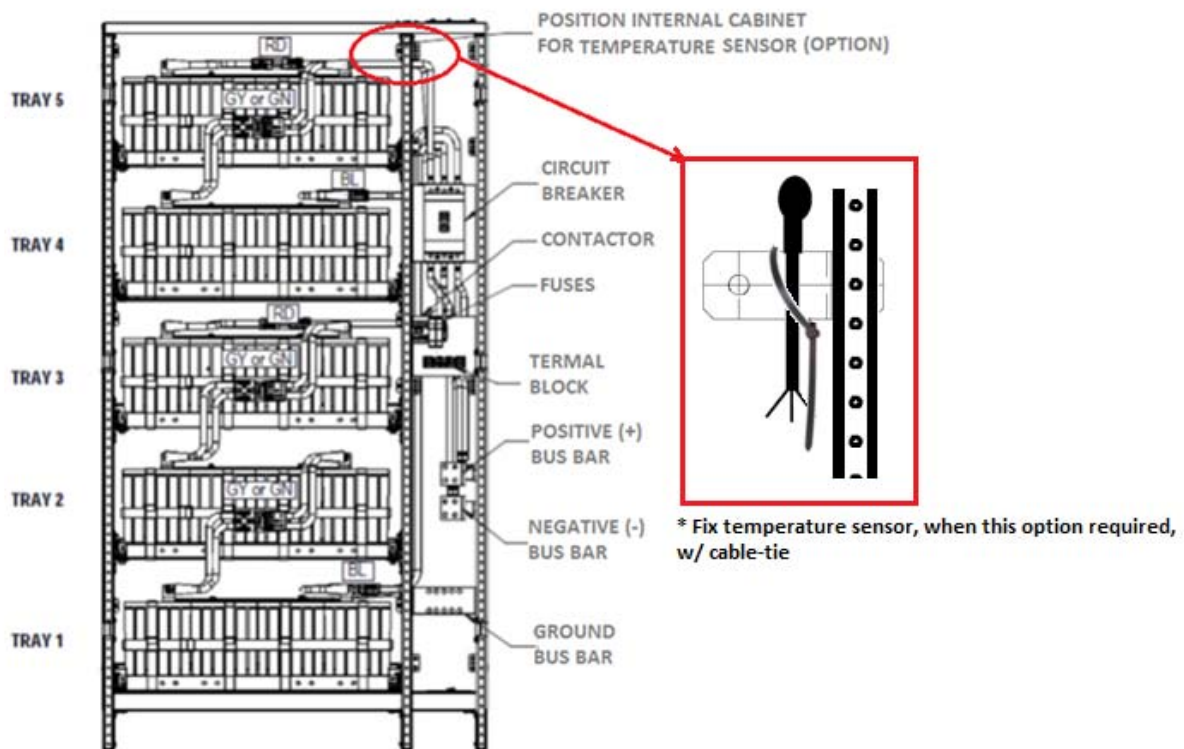

Fig. 13- Battery cabinet assembled

Color table connectors	
Colors	Abbreviation
Blue	BL
Red	RD
Gray	GY
Green	GN



When the Battery Cabinet is full assembled reinstall all panels



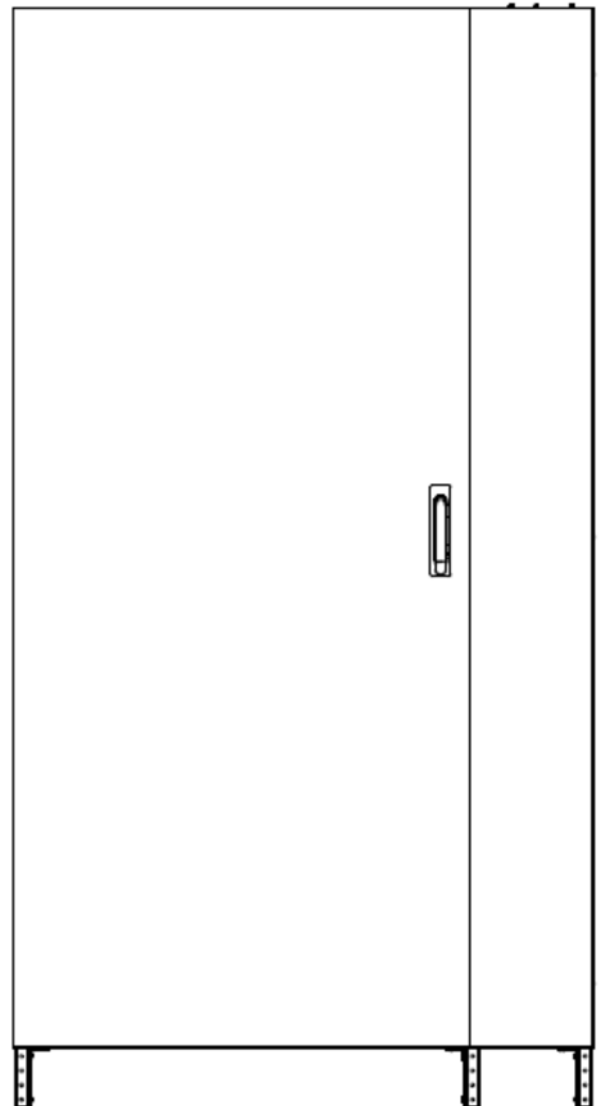
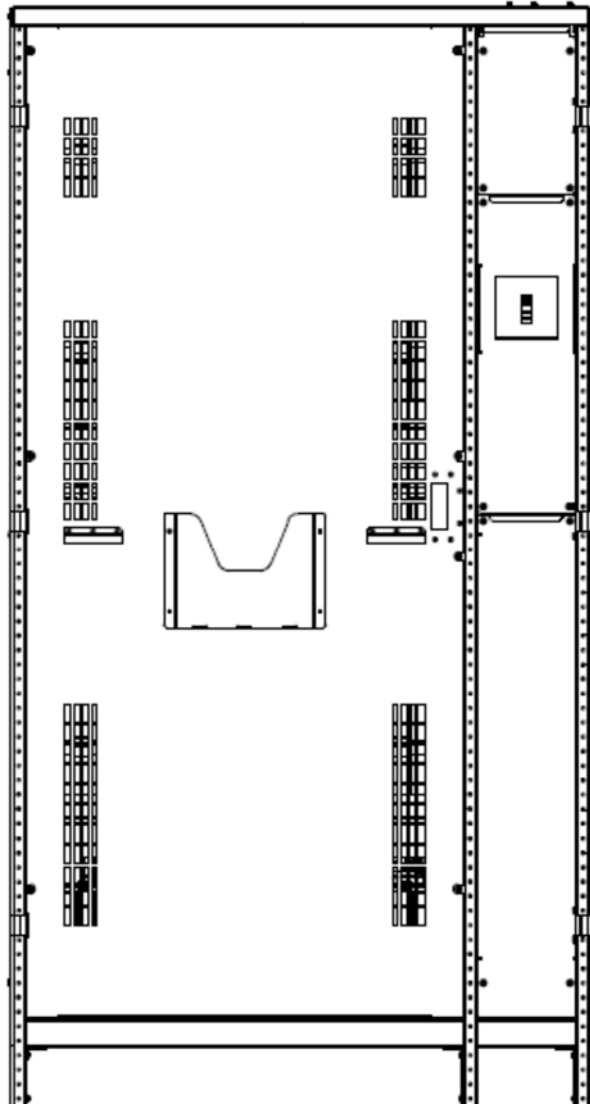

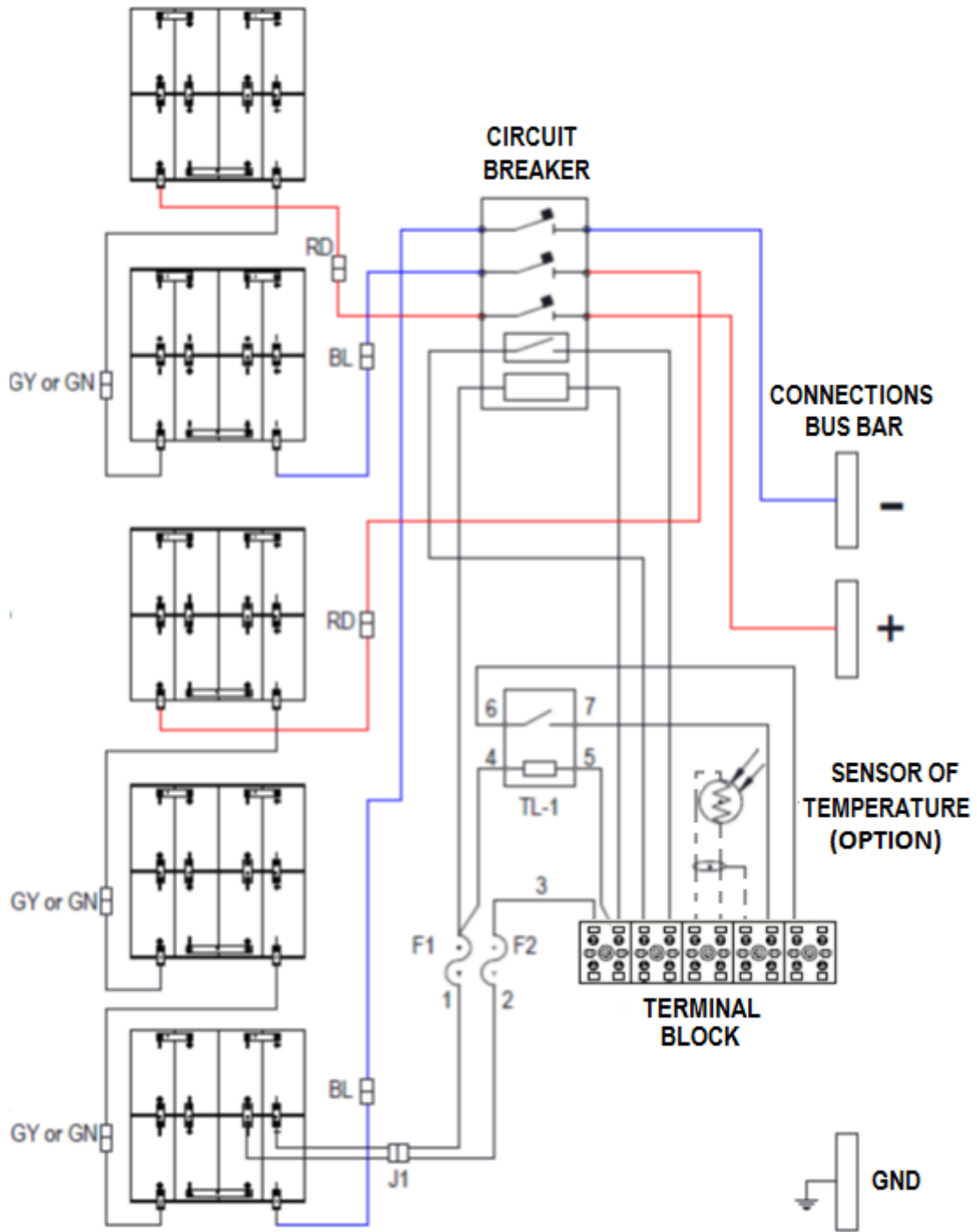

**ELECTRICAL DRAWING**

## SECTION 5

### CONNECTION TO UPS SYSTEM



The ground terminal of battery cabinet must be connected with ground terminal of UPS cabinet. NEC article 250 for identify grounding system and sizing grounding conductors

### POWER CABLE CONNECTION

Table 4 - sizing conductor battery

battery cabinet	OCP device *	Field wiring	bolt size	torque
Model	A	[q.ty] x AWG	in / mm	lbf-ft /Nm
BBX 1900 480V UL L6 3U (55Ah)	200A	4/0 or [2] x 2	3/8 " / 10	22 / 30
BBX 1900 480V UL L8 3U (100Ah)	300A	[2] x 2/0		

\* Included in battery cabinet



cables are to be connected to the field terminals through Listed cable lugs suitable for cable size . When using crimp type lugs, follows the manufacturer's instructions for both crimp tool and lug



**CAUTION:** Use at least 75° C rated copper wire. Minimum wire size is based on full load ratings applied to NEC Code Table 310-16. Code may require a larger AWG size than shown in this table because of temperature, number of conductors in the conduit, or long service runs. Follow local requirements.

#### CABLE ENTRY OF BATTERY CABINET IS PROVIDED EITHER FROM BOTTOM OR TOP.



Only properly trained and qualified personnel should perform the UPS installation and initial start up

- 1) Make sure that the UPS is not powered.
- 2) Make sure Battery Circuit breaker is in "off" position
- 3) Make sure that the cables to connect to UPS cabinet are correctly arranged
- 4) Make sure the cables are correctly marked with polarity indication (+ and – or red and black)
- 5) Connect positive terminal of battery cabinet (+) with positive terminal of UPS cabinet, connect negative terminal of battery cabinet (-) with negative terminal of UPS cabinet (see figure).



**DO NOT CLOSE BATTERY CIRCUIT BREAKER BEFORE UPS IS OPERATING**

**BATTERY CABINET**  
**55-100Ah**  
 (CABLE INPUT TOP and BOTTOM)

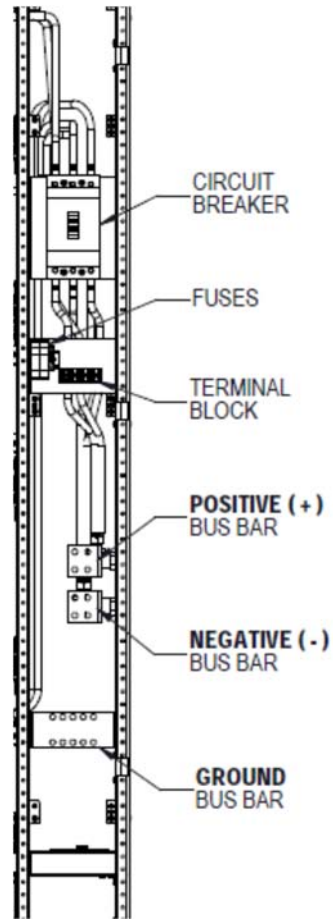
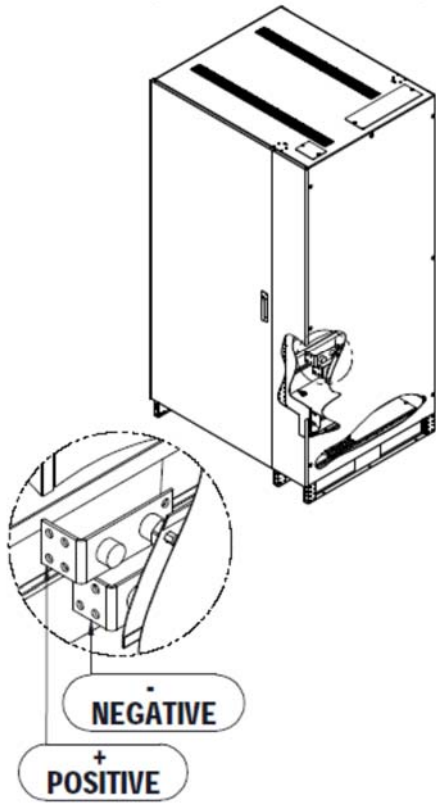

UPS 65 ÷ 125kVA  
 CABLE INPUT BOTTOM

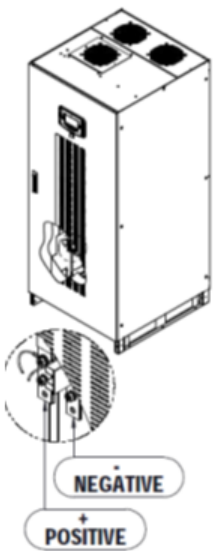

UPS 160 ÷ 250kVA  
 W/O TCE  
 CABLE INPUT BOTTOM

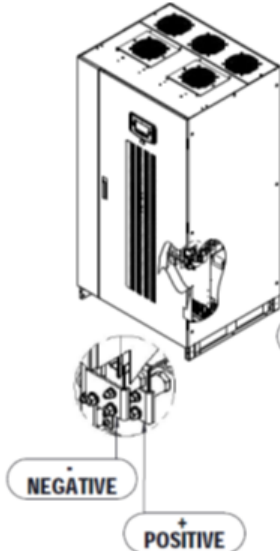

UPS 160 ÷ 250kVA  
 W/ TCE  
 CABLE INPUT TOP AND BOTTOM

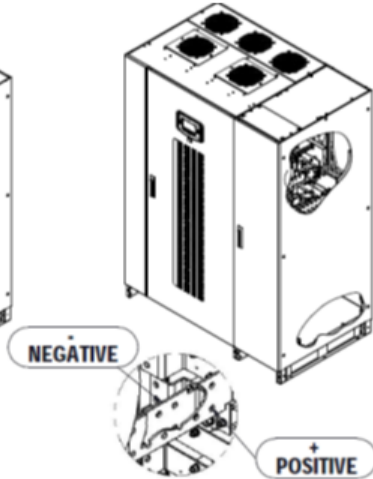

UPS 300 ÷ 500kVA  
 W/ and W/O TCE

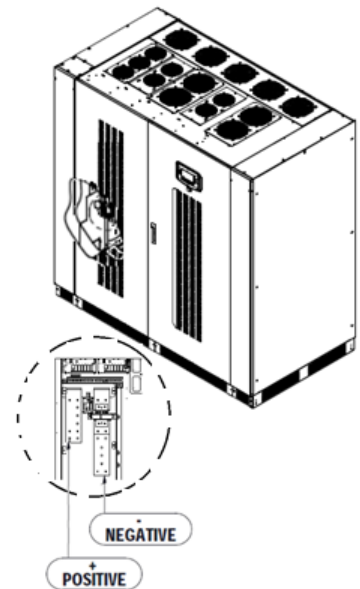

CONNECTION UPS 65+125kVA  
TO BATTERY CABINET

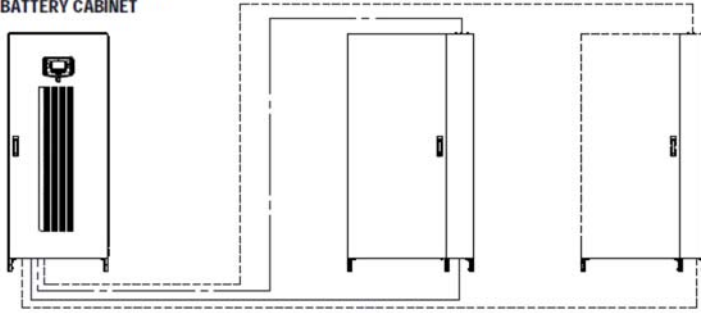

CONNECTION UPS 160+250kVA W/O TCE  
TO BATTERY CABINET

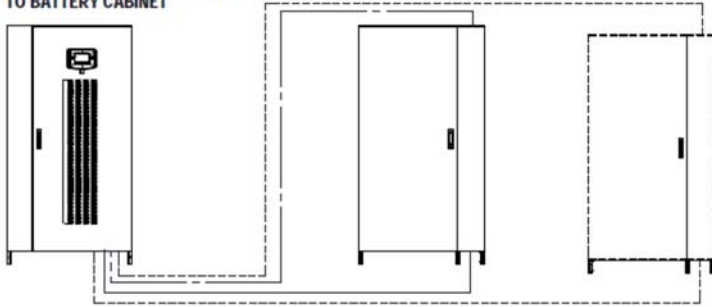

CONNECTION UPS 160+250kVA W TCE  
TO BATTERY CABINET

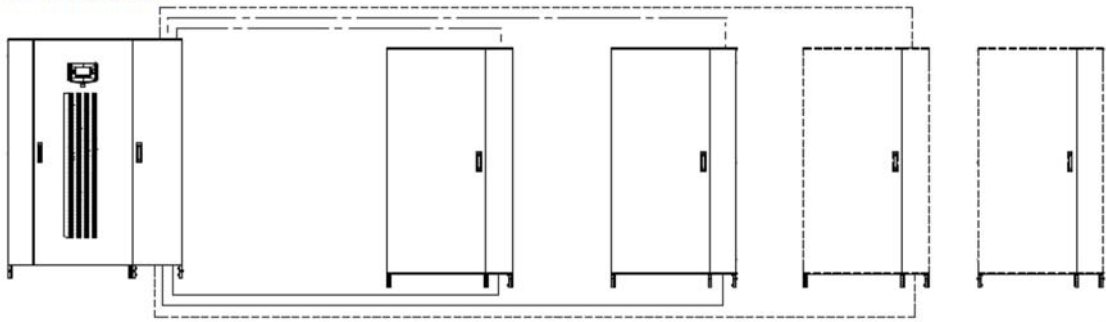

CONNECTION UPS 300+500kVA W/O TCE  
TO BATTERY CABINET

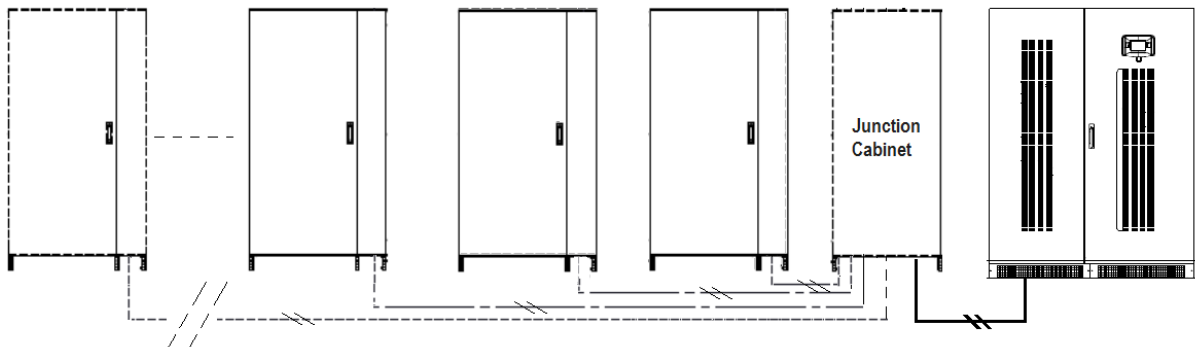

CONNECTION UPS 300+500kVA W TCE  
TO BATTERY CABINET

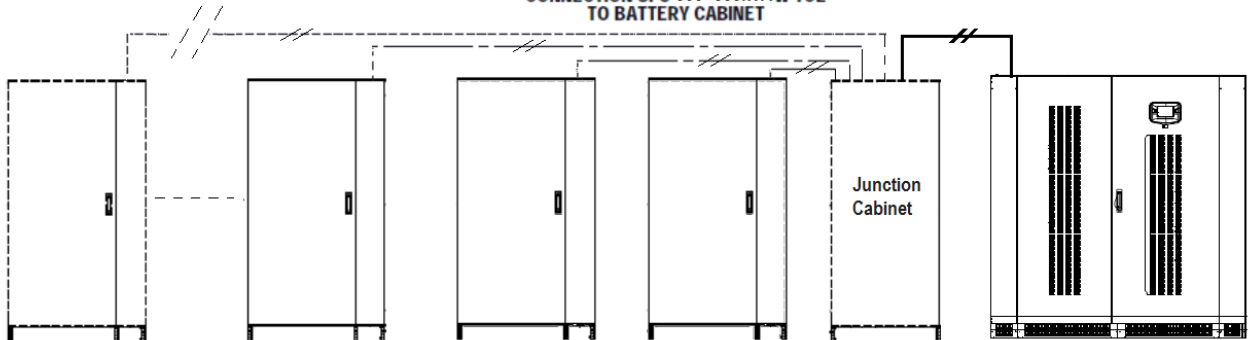

## AUXILIARY CABLES CONNECTIONS (OPTION)



The signals described in this paragraph are not part of safety circuit, since they are not insulated from dangerous voltage.

Do not connect to SELV circuit

Connect to UPS only using the cables provided (600V minimum rating).

### Circuit breaker interface

- 1) If opening of Battery Circuit Breaker is required for EPO (Emergency Power Off) operation, Terminals SWBAT COIL must be connected to terminals SWBAT COIL of UPS cabinet.  
In case of 2 or more Battery Cabinets Installed, connect terminals SWBAT COIL of second Battery Cabinet to SWBAT COIL II of first battery cabinet and so on (see Fig. 15)
- 2) Battery Circuit Breaker Open, aux contact signal requires:  
Connect terminals AUX SWBAT to terminals AUX SWBAT of UPS cabinet.  
In case of 2 or more Battery Cabinet installed, connect the terminals in parallel (see Fig. 15).



For connection of these signals, 2 cables 22AWG style 2516 (600V) are supplied, as listed in section 3

### Temperature sensor (option) for adjusting charging voltage

The battery cabinet is provided with a temperature sensor kit, when this option is present.  
If the compensation of charging voltage, as function of Battery Cabinet temperature, is required, connect terminals "Battery Temp.Sensor" to terminal "Battery Temp.Sensor" of UPS cabinet, using shielded cable 2x 22awg style 4516, supplied as in the component list, section 3 see.



In case of two or more Battery Cabinets installed, only one temperature sensor must be connected.

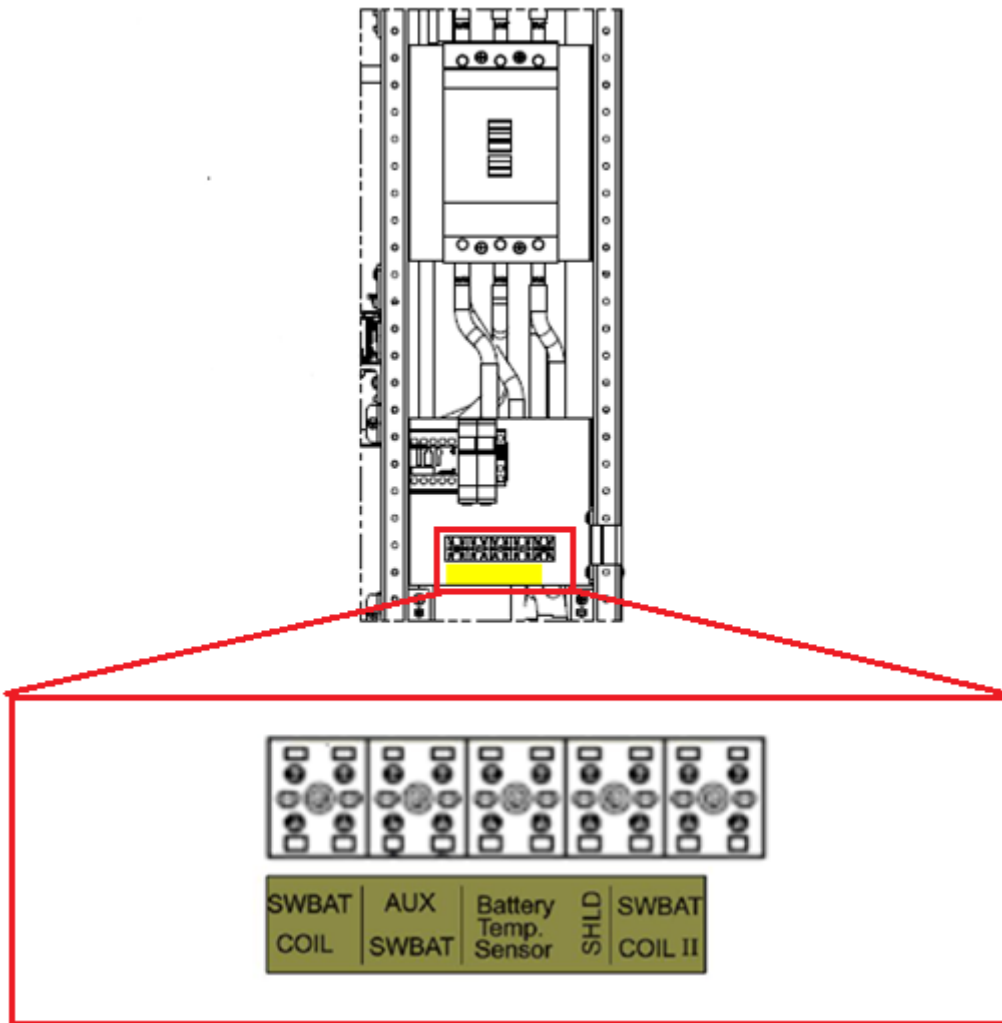

Fig. 14- battery cabinet terminal block detail

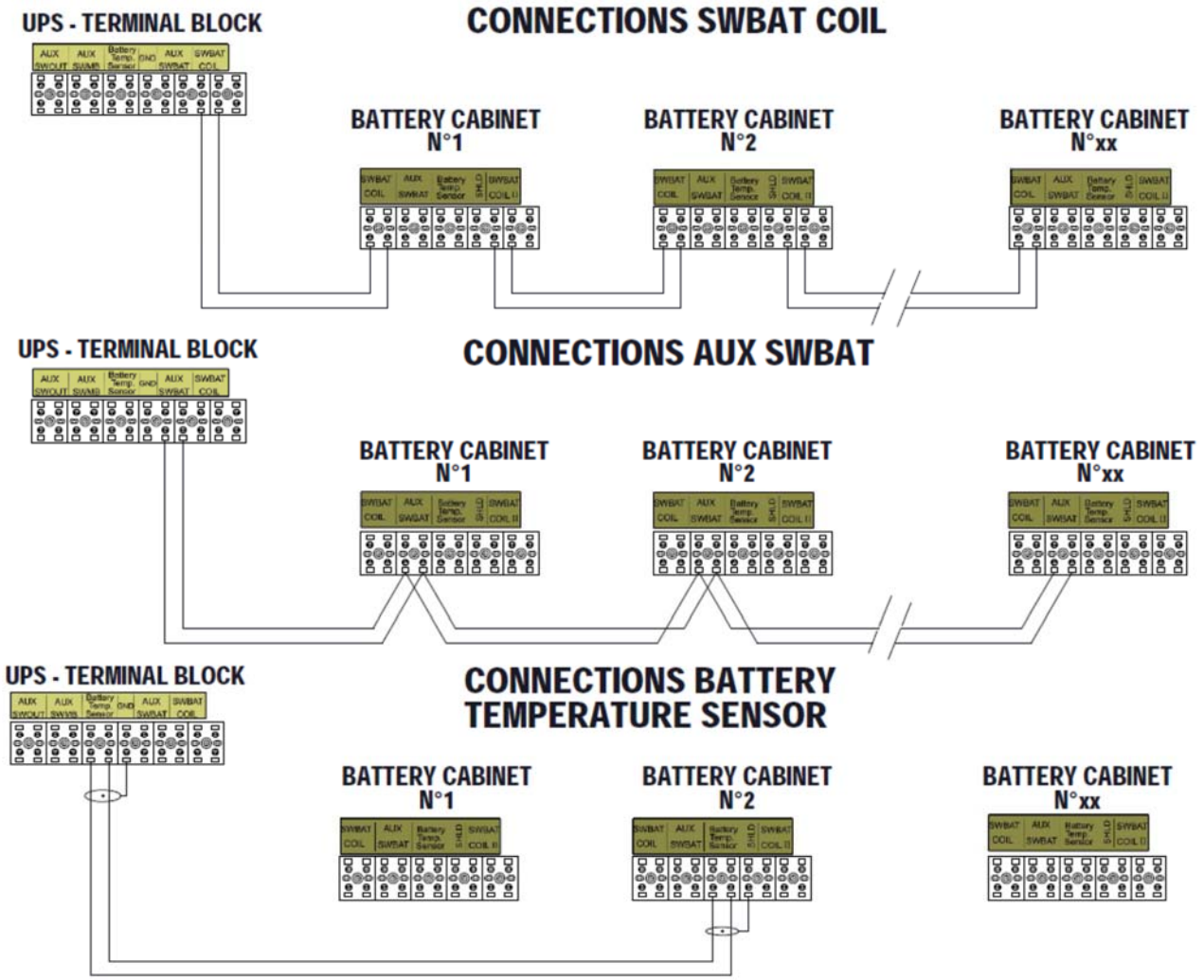

Fig. 15 - Connections diagram of auxiliary signals